

TEACHER'S CHECKLIST & INFORMATION

<p>Date & Location</p> <p>March 18-19-20, 2012</p> <p>Laval Junior & Laval Liberty High Schools</p> <p>3200 Souvenir Ouest Chomedey, Laval, QC H7V 1W9</p> <p>Two Schools - One building</p>	<p>General site & Including Judging Rules www.exposciences.qc.ca www.sciencetech.ca</p> <p>Student's site www.ScienceTech.ca/ScienceProject</p> <p>Teacher's site www.ScienceTech.ca/ScienceTeacher</p> <p>Judge's site www.ScienceTech.ca/ScienceJudge</p> <hr/> <p style="text-align: center;">Mailing Address</p> <p style="text-align: center;">Laval Liberty High School Attention: Michael Quinn 3200 Souvenir Ouest Laval, Québec H7V 1W9</p>
---	--

You are required to hand in to the MRSTF:

Student Online Registration	March 2, 2012 (online)
School registration, cheque, student forms, & 6 copies of project report	March 2, 2012 (mailed)

Contact Info	
MRSTF 2012 Contact Person:	Michael Quinn mquinn@swlauriersb.qc.ca 450-621-5600 local 1372
MRSTF 2012 Chief Judge:	Heather McPherson judge@sciencetech.ca
Educational Alliance for Science & Technology	Barry Hannah barry@sciencetech.ca

Notice: *Schools that do host local fairs are allowed a maximum of nine (9) projects. Schools that do not host local fairs are allowed a maximum of four (4) projects. Registration will be capped at 200 projects. If this total is reached prior to the registration deadline, registration will close without warning.*

<input type="checkbox"/>	School Registration (1 page – at the end of this document with teacher/principal signatures)
<input type="checkbox"/>	Your school's payment for all <i>projects registered</i> and T-shirts, as per your order
<input type="checkbox"/>	Payable to EAST-AEST or "Educational Alliance for Science & Technology"
<input type="checkbox"/>	<p>Please verify each submitted project to include:</p> <ul style="list-style-type: none">• <i>Science Fair Registration Form 2012</i><ul style="list-style-type: none">• Printed from the online system• Signed by participants and their guardians (if applicable)• <i>Forms from the online system:</i><ul style="list-style-type: none">- <i>Registration form (signed by student(s) and parent (if applicable))</i>- <i>Medical file (signed by student(s) and parent (if applicable))</i>- <i>Awards (signed by student(s) and parent (if applicable))</i>- <i>Forms (as applicable)</i><ul style="list-style-type: none"><i>i. Form 4.6A – Continuation of Project for a Second Year</i><i>ii. Form 4.8A – Contribution form for a recognized institution</i><i>iii. Form 6.10.3A – Free Consent for project requiring participation of human subjects (low-and-high risk)</i><i>iv. Form 6.11.A – Approval of a project requiring participation of human subjects (high-risk)</i><i>v. Form 6.12.A – Approval of a project requiring participation of human subjects (low-risk)</i>• <i>6 printed paper copies of project report mailed to Heather McPherson c/o Laval Liberty High School</i> <p style="text-align: center;"><i>Remind students to keep a copy of all documents for themselves!</i></p>
<input type="checkbox"/>	Your judges recruited for the regional level (online registration opens at the end of November on the www.exposciences.qc.ca website – direct link to the judge registration page can be found at www.sciencetech.ca/sciencejudge)

Regional Judges

Schools entering 7 to 9 projects - must provide at least 6 judges;
Schools entering 3 to 6 projects must provide at least 4 judges;
Schools entering 2 or 1 project(s) must provide at least 1 judge.

Online registration for judges can be accessed from www.sciencetech.ca/sciencejudge

Major Changes

- Students will be asked to wear their mandatory MRSTF t-shirts so that we can clearly identify students.
- Special parking arrangements will be made for Tuesday – news to follow.
- School visits to science fair are encouraged and free. Please communicate with the MRSTF 2012 contact person.
- The teacher-in-charge should receive the student's forms that require signature. Please discourage your individual students from submitting their forms directly.
- Students will require the teacher's email address (and, if a two-person team, their partner's) when registering their project.
- Photocopies of 5-page reports must be submitted this year; students should make sure the paper copy matches what they submit on-line as only the digital version is passed on to the provincial competition. The template for their report and the mandatory cover sheet is online too
- Note: Winners who proceed to the next level fair will not be able to modify their project report – the one submitted online at the regional will automatically be transferred to the provincial committee. Please respect the project report rules

School Visits and Chaperones – Contact the MRSTF Contact Person to arrange for a school visit to the Fair. A chaperone may be any person designated by the institution to be a legal agent of that institution. They are responsible for all persons from that institution.

Next-level Fair Chaperones

Chaperones look after our students. Moreover, they look after our Regional winners' best interest at the next level science fair (provincial and international).

- For the provincial science fair, we invite the schools of the selected winner to send a member (teacher, parent or another responsible adult) to act as a chaperone for our 12-projects delegation.
- We are recommending that the school of each selected exhibit contribute \$25 as part of an honorarium. This will be a combined total of \$300 for all provincial chaperones and international varies accordingly.

Project Types

Effective 2005, the Montreal Regional Science & Technology Fair accepts only certain project types from a particular grade level. (See table below).

Level	Experimentation	Design	Study
Senior 2	Yes	Yes	Yes
Senior 1	Yes	Yes	No
Intermediate	Yes	Yes	No
Junior	Yes	Yes	No

Regional project admission is only experimentation and design-type projects. Although individual schools may have local projects that are study based, schools are not allowed to forward them to the regional science fair. After review by a judging committee, a project may be refused entry or be ineligible for all prizes and/or without refund. The Chief Judge will notify the school representative of the final decision.

However, the exception will be for Senior 2 where Study is allowed if it is "Applied Research". The project is designed to solve practical problems rather than just to acquire knowledge. It is the understanding of a phenomenon and, more importantly, improving on the situation. This is different from "Basic Research" where it is an expansion of human knowledge but it does not improve on the situation.

Student Code of Conduct

Congratulations on your selection as a participant of the Montreal Regional Science & Technology Fair. Please guidelines apply when you are involved with a MRSTF-sponsored event. We hope your days are filled with pleasant memories and new friendships!

1. **Ethics Statement** – Scientific fraud and misconduct is not condoned at any level of research or competition. Plagiarism, use or presentation of other researcher's work as one's own and fabrication or fabrication of data will not be tolerated. Fraudulent projects will fail to qualify for competition at the regional fair or other higher-level fairs.
2. The use of tobacco products, alcoholic beverages and/or other drugs is prohibited.
3. **Official Montreal Regional Science & Technology T-shirt is to be worn at all times**
4. Be respectful and considerate of others at all times. Remember, you have been selected to represent your school. Make all those at your school proud of your behaviour. Be friendly and courteous at all times. Make a special effort to make **new** friends. Be especially polite when listening to keynote speakers, as it is often very difficult to hear when the entire MRSTF convention assembles. The same applies to the awards ceremonies.
5. Attendance is mandatory throughout all the designated hours.

Consequences: If any rule violations occur, the violator may be sent home immediately, at the parent's expense.

Abridged version from ISEF

Specific Rules for the 2012 Hydro Quebec Montreal Regional Science & Technology Fair

This supersedes Section 7 of the “2012 Science Fair Rules” and is applicable to the MRSTF only.

- 7.1 The only display booths authorized will be in black InteFoam (structure or framework) and **will be provided by the MRSTF.**
- 7.2 Booths will be set up on the tables with the project displayed on the front.
- 7.3 The project title must be displayed **inside** the display areas mentioned in Item 7.1
- 7.4 Projects (all elements combined) must not exceed the dimensions specified in Item 7.1
Please note dimensions are similar to the provincial science fair (section 8).
- 7.5 All signs affixed to the booths must be **plastic-coated** (sticky tape will be provided by MRSTF). We suggest that you first stick your signs onto a large piece of cardboard before laminating them. For decorative purposes, posters may be affixed to the booth. They must be applied directly to the booth in order to avoid a chimney effect (air pockets must be minimized)
- 7.6 No decorative items should be affixed permanently or in a manner that will modify the booths.
- 7.7 Elements not affixed to the booth may be placed on the table in the space described in Item 8.
- 7.8 Titles and other signs must be within the above stated dimensions.
- 7.9 Corrugated cardboard, foam core, Styrofoam, foam rubber and coroplast are prohibited for decorating and for use in scale models.
- 7.10 No roof, dome, fabric or other method of covering the top or sides of the booth will be accepted.
- 7.11 The project display may include pictures of participants if prior permission has been obtained. Projects dealing with forensic science topics must preserve the anonymity of any human victims, and projects displays must avoid sensational or gratuitous, macabre images.

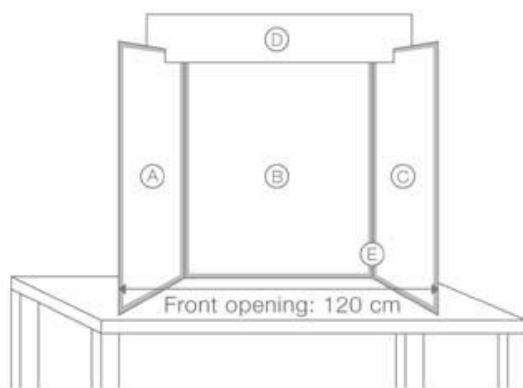

- A - Display area 68 (L) x 112 (H) cm
- B - Display area 92 (L) x 112 (H) cm
- C - Display area 68 (L) x 112 (H) cm
- D - Area reserved for MRSTF
- E - Shaded areas must be left empty.

NOTE: if the project is selected to the provincial science fair, the participants will be required to adjust their project to conform to the provincial science fair specific rules (see Section 8 of the Science Fair Rules).

Online Registration

- Access via the Student page (www.sciencetech.ca/scienceproject)
- When asked for region, indicate “Montreal Regional Science & Technology Fair”
- Browser – works best under Internet Explorer with cookies & javascript enabled; please allow for popups
- Students will require
 - the teacher’s email address (use the teacher-in-charge)
 - if a two-person team, their partner’s email address
 - parent’s telephone numbers (office, cellular)
 - medical information
 - about 30 minutes
 - submit before the deadline because the system will lock the student out.

Students should not send their package directly to the CLS.

Please have the students give their documents to the teacher-in-charge who should prepare one school package and mail it to **Michael Quinn** (on the front page)

School Registration

<p>INSTRUCTIONS:</p> <p>Please remember to visit www.ScienceTech.ca/scienceteacher and complete the online form (i.e. chaperones name and local fair statistics).</p> <p>Please return this school registration form, your students' exhibit registration packages and the appropriate fees per project</p>	<p>MAIL TO:</p> <p style="text-align: center;">Laval Liberty High School Attention: Michael Quinn 3200 Souvenir Ouest Laval, Québec H7V 1W9</p>
--	--

**Payable to “EAST-AEST” or “Educational Alliance for Science & Technology”
 no later than Friday, March 2, 2012 at 17:00**

Name of School: _____

School Telephone Number: _____ FAX _____

Name of Contact Person: _____

E-Mail Address: _____

Home Telephone Number: _____

Solo-student Projects Entered: _____ x \$85 = _____

Two-student Projects Entered: _____ x \$95 = _____

Extra T-shirts Needed: _____ x \$10 = _____

NOTE: For projects coming from schools that are not from one of the **EMSB, LBPSB, SWLSB, RSB, or QAIS** schools, there is an additional **mandatory E.A.S.T. membership fee of \$150** per project payable upon project submission and registration.

Notice

1. T-Shirts are mandatory and automatically included in the pricing. Students will pick up their sizes on site.
2. A late penalty of \$20 dollars (CDN) will be levied to each INCOMPLETE project (solo: \$85 + \$20 or duo: \$95 + \$20) submitted by a school past the due date. In special circumstances, the MRSTF may waive the penalty policy if advance arrangements – and in writing – are made with the host committee.
3. The school of a selected next-level fair winner – in conjunction with the guardians – will contribute to registration fees (SES \$275Cdn per student, CWSF \$450Cdn per student and ISEF \$725 per student)
4. The school of a selected next-level fair (provincial, national and international) winner will assist in providing a chaperone for the delegation and a \$25 honorarium per project of their school will be provided.
5. Schools hosting a local science fair are allowed a maximum of 9 projects; schools without local science fairs are allowed a max of 4 projects. In both cases, the minimum number of regional judges will be recruited by the school.
6. Our students' project type reflects the stated grade levels. We acknowledge that the judging committee may refuse (and without refund) a project due to the MRSTF policy on project type from a particular grade level.

Please check one of the following:

- We, the undersigned, attest to the fact that our school **will hold** a local Science Fair on (date) _____ and we are selecting our school projects according to the evaluation criteria used in the MRSTF;
- We, the undersigned, attest to the fact that our school **will not** be holding a local Science Fair in this academic year but the individual projects are evaluated according to the criteria used in the MRSTF.

Signature of Principal :		Date:
Signature of Contact Person:		Date